

Pan coating technology

GMPC II MULTI-LAB

FILM COATING

GMPC II MULTI-LAB



Glatt[®]

The very best for your laboratory

The innovative GMPC II Multi-Lab from Glatt

Total flexibility

Top-quality coating. For new ideas and the best products.

- Film coating in the range from approx. 1 kg to approx. 10 kg.
- 4 interchangeable drum sizes with working volumes of 2.5 l, 5 l, 9 l and 12 l.
- 2 or 3 ABC nozzles.
- For aqueous and organic processes.

First for clinical sample production

The highest of requirements apply in the manufacture of clinical samples. Choose the trouble-free solution: GMPC II Multi-Lab.

- Easy-to-clean design.
- Comprehensive process documentation.
- Qualification package optional.
- Validation of processes.
- Optional HEPA-filtered air inlet.
- All relevant materials FDA compliant.



Form and function taken to perfection

**GMPC II Multi-Lab.
Glatt quality.
In every detail.**

Optimum process control

Raise your expectations with ProcessView! Fast and simple process control providing a convincing solution.

- Touch-screen control.
- Rotating operating panel.
- Perfect ergonomics for the operator.
- Integrated recipe management.

Outstanding handling and integrated technology.

Perfect solutions and sophisticated design. The GMPC II Multi-Lab offers all the advantages of integrated technology and top-quality finish.

- Simple filling and patented Mini Smart-Scoop® for simple discharge.
- 4 exchangeable pans with central fixing, very easy to replace.
- Large front door, easy-to-clean process areas.
- Ergonomically arranged connections. Perfect integration.
- Unique work surface made of synthetic granite. Resistant to solvents, scratch-proof and impact-proof. It still looks like new even after years of use.
- Innovative nozzle arm, removable and rotatable. Nozzle position easily adjustable.

Modular design

Benefit from maximum flexibility. The integrated extra modules mean that all options are available to you, either now or later. You are well prepared for the future.

- Dehumidification of inlet air.
- Large exhaust filter for dust-intensive coating processes.
- Additional storage space for process accessories.

Plug & Play

Just connect it up and you're off!

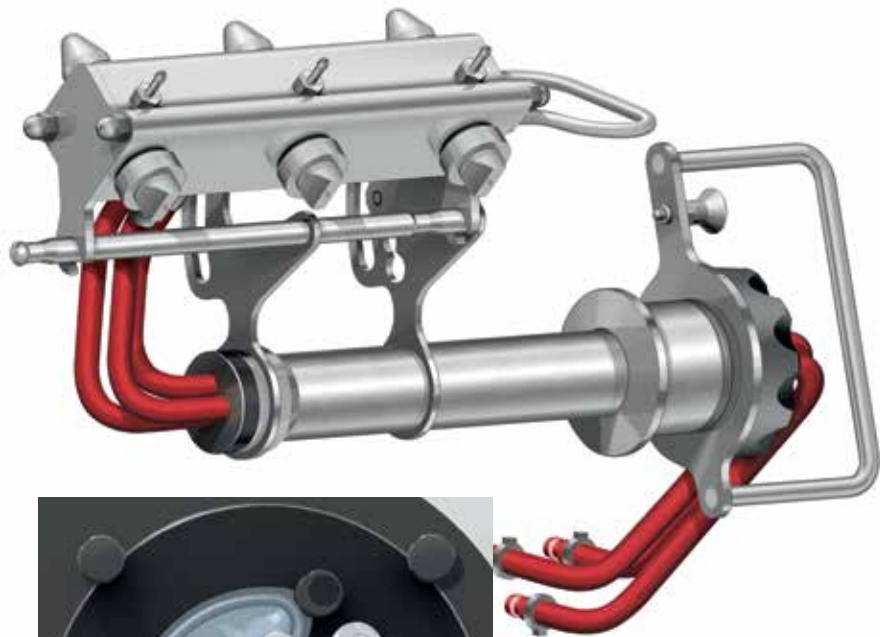

Technical data / Addresses

GMPC II Multi-Lab

Exchangeable pans	Working volume*	Litres	2.5	5	9	12
	RPMs	1/min	1 - 20			
	Motor rating	kW	0.25			
Ventilators	Air volume	Nm ³ /h	50 - 300			
	Motor rating	kW	3			
Air heater	Max. inlet air temp.	°C	80			
	Max. electr. heating capacity	kW	7			
Spray system	Spray system		Binary nozzles			
	Number		2	2	3	3
	Pump motor	kW	0.06			
Air filter	Inlet 1	acc. to EN 779	F 7			
	Inlet 2	acc. to EN 779	F 9			
	Inlet 2 (optional)	acc. to DIN EN 1822	H 13			
	Outlet air	acc. to EN 779	F 9			
	Exhaust (optional)	acc. to DIN EN 1822	H 13			
Power	Operating voltage	V	400			
	Frequency	Hz	50 / 60			
	Total connected load	kW	12			
	Max. compressed air consumption	Nm ³ /h	30			
	Max. compressed air consumption		6 bar			
	Connector		5-pole CEE form			
Dimensions	Height	mm	1950			
	Width	mm	2520			
	Depth	mm	980			
Weight	GMPC II Multi-Lab	kg	approx. 1000			

*Max. working volume, min. working volume 50% (Subject to technical alterations)

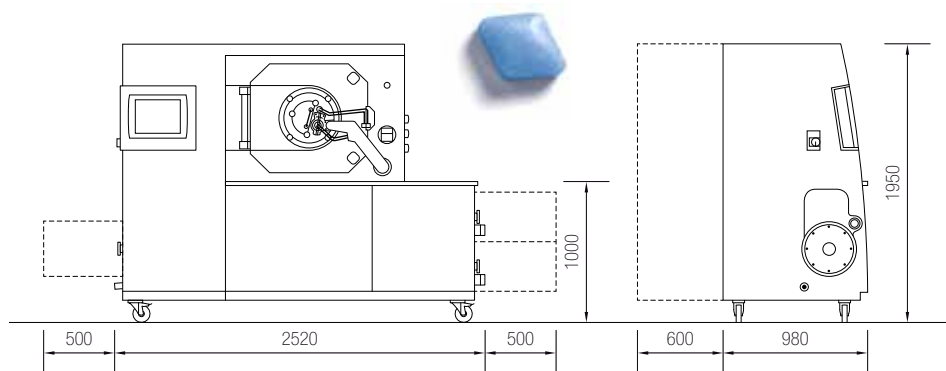

Glatt GmbH Process Technology

Werner-Glatt-Straße 1
79589 Binzen / Germany
Phone: +49 7621 6640
Fax: +49 7621 64723
e-mail: info@glatt.com

Glatt Maschinen- & Apparatebau AG

Kraftwerkstrasse 6
4133 Pratteln / Switzerland
Phone: +41 61 8264747
Fax: +41 61 8264848
e-mail: info@glatt.com

Glatt Ingenieurtechnik GmbH

Nordstraße 12
99427 Weimar / Germany
Phone: +49 3643 470
Fax: +49 3643 471231
e-mail: info@glatt-weimar.de

Glatt Air Techniques Inc.

20 Spear Road
Ramsey, NJ 07446 / USA
Phone: +1 201 8258700
Fax: +1 201 8250389
e-mail: info@glattair.com

Glatt Ingenieurtechnik GmbH

ul. Obrucheva, 23, korp. 3
117630 Moscow / Russia
Phone: +7 495 7874289
Fax: +7 495 7874291
e-mail:
info.glatt-moscow@mastertelecom.ru

Glatt Pharmatech SASU

Parc Technologique
6, rue Louis Néel
21000 Dijon / France
Phone: +33 3 80743264
Fax: +33 3 80744395
e-mail: info@glatt-pharmatech.fr

Glatt Protech Ltd.

Swannington Road
Cottage Lane Ind. Est.
Broughton Astley
Leicester LE9 6TU / Great Britain
Phone: +44 1455 285858
Fax: +44 1455 285510
e-mail: info@glatt-protech.co.uk

www.glatt.com

